



RÜZGAR TÜRBİNLERİNDE GARANTİ SONU KONTROL ÇALIŞMALARI (EOW)

Hazırlayan

Nihat TONGUC

Who We Are

About our energy group



Founded 1997 to give a service in wind industry and growing with new renewables year by year.

Who We Are

About our energy group

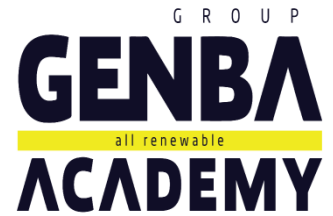

ALL RENEWABLE!

GLOBAL MAP

GENBA EU
SINCE Jan.2018

GENBA TURKEY
SINCE 1998

GENBA PAKISTAN
SINCE 2014

GENBA MOROCCO
SINCE NOV.2017

Management Office,
Training Center
Manufacturing Area
R&D Project department

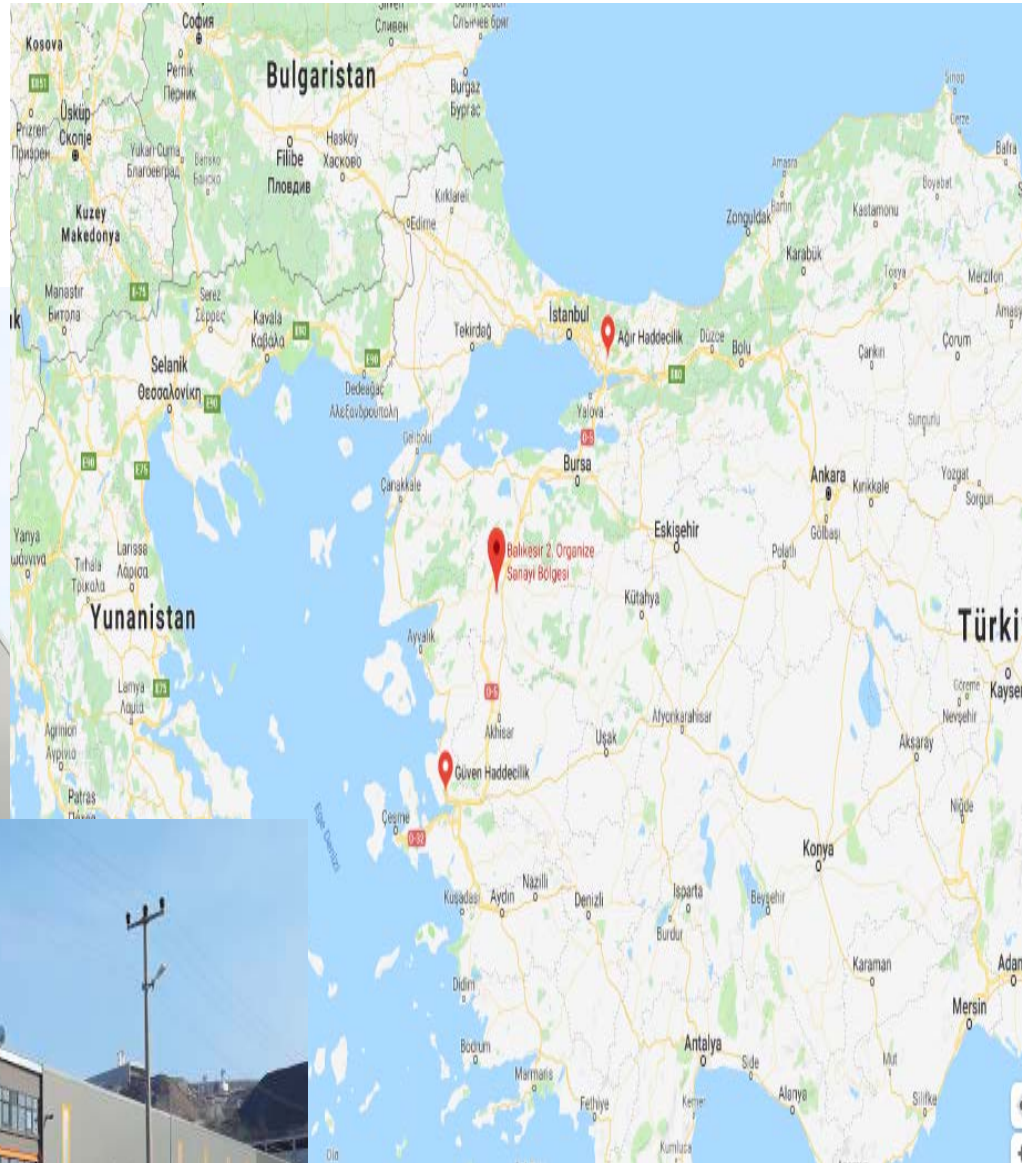

RÜZGAR TÜRBİNİ NEDİR VE NASIL ÇALIŞIR ?

Rüzgar türbini, rüzgardaki kinetik enerjiyi kanatlar ve rotor yardımıyla önce mekanik enerjiye daha sonra da elektrik enerjisine dönüştüren sistemdir.

Rüzgar Türbini bileşenleri

- Kanat
- Nacelle
- Kule
- Temel

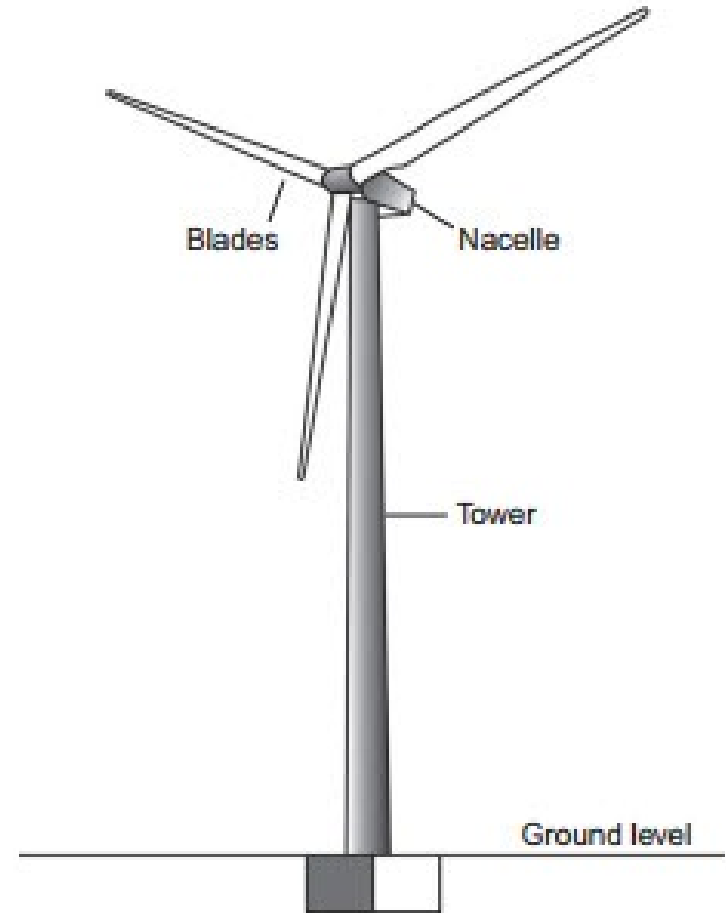

RÜZGAR TÜRBİNİ KURULUM AŞAMASI ?

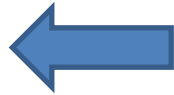
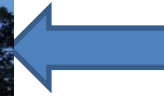
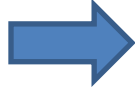
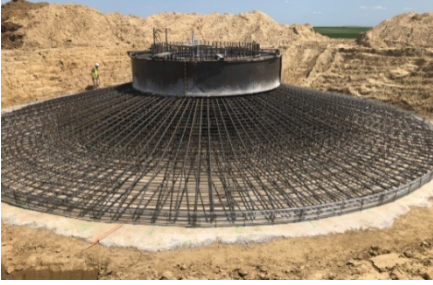

EOW (Garanti Sonu inceleme tanımı)

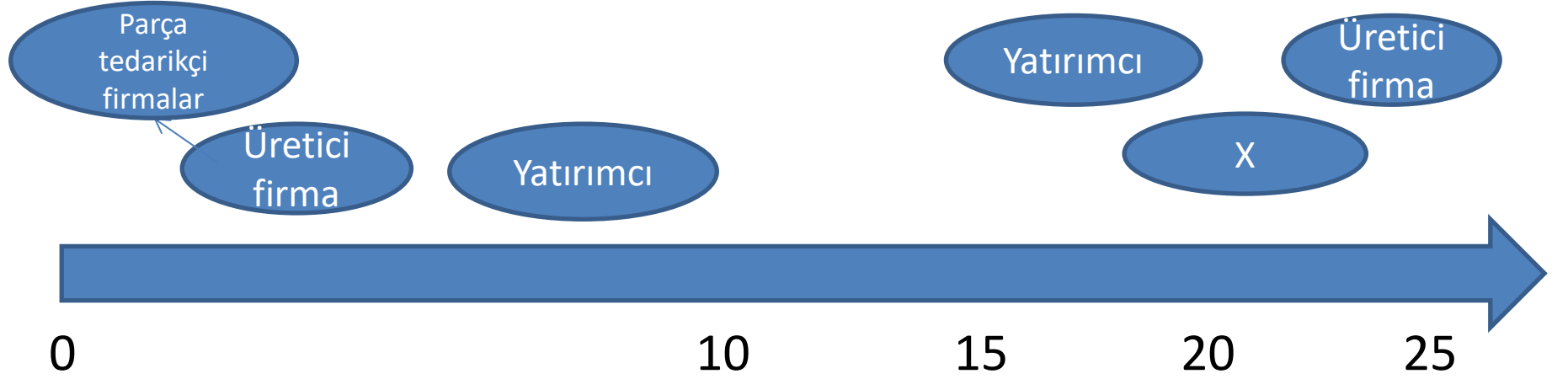

EOW incelmesi : Garanti sonu türbin incelemesi, Türbin ve türbin içerisinde bulunan türbine bağlı parçaların garanti /servis anlaşması bitmeden veya revize edilmeden önce gerekli kestirimci incelemelerin yapılması ve tespit edilen hasarların garanti kapsamına alınması için yapılan incelemelerdir.

RÜZGAR TÜRBİNİ BİLEŞENLERİNİN MALİYET ORANLARI

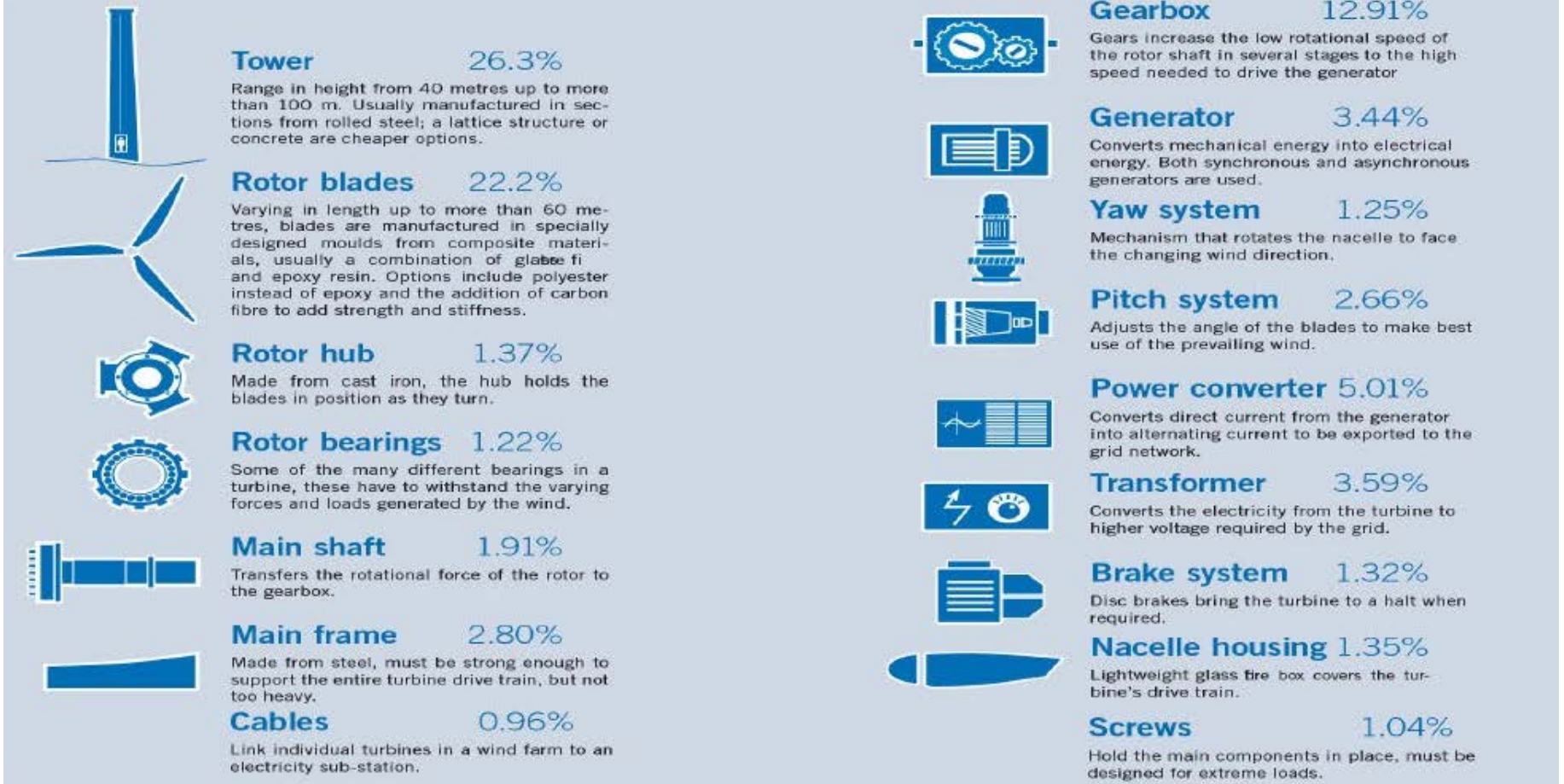

Gearbox : %12,91

Tower : %26,3

Blades : %22,2

Kaynak: NREL

RÜZGAR TÜRBİNİ BİLEŞENLERİNİN MALİYET ORANLARI

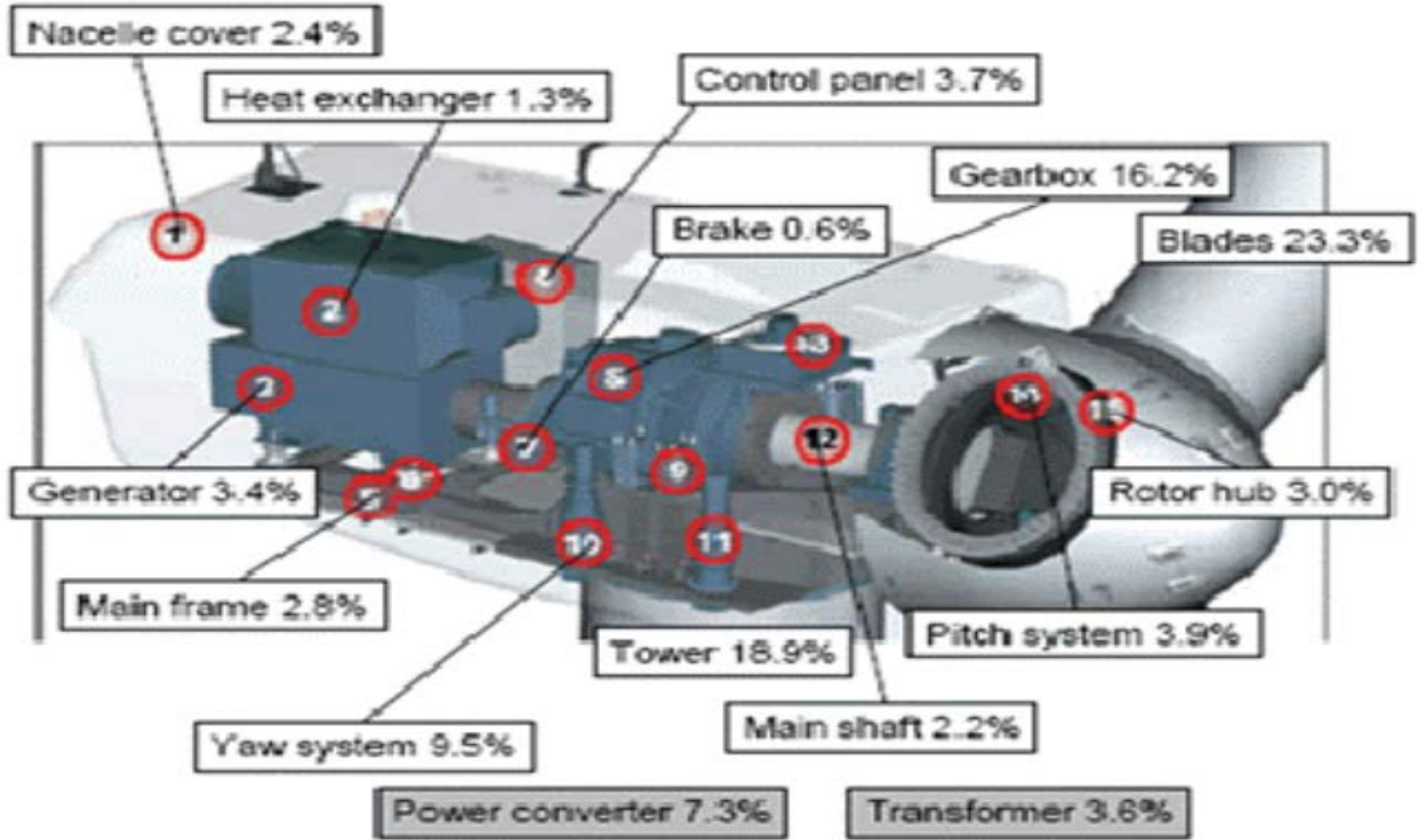

Gearbox : %16,2

Tower : %18,9

Blades : %23,3

RÜZGAR TÜRBİNİ BİLEŞENLERİNİN MALİYET ORANLARI

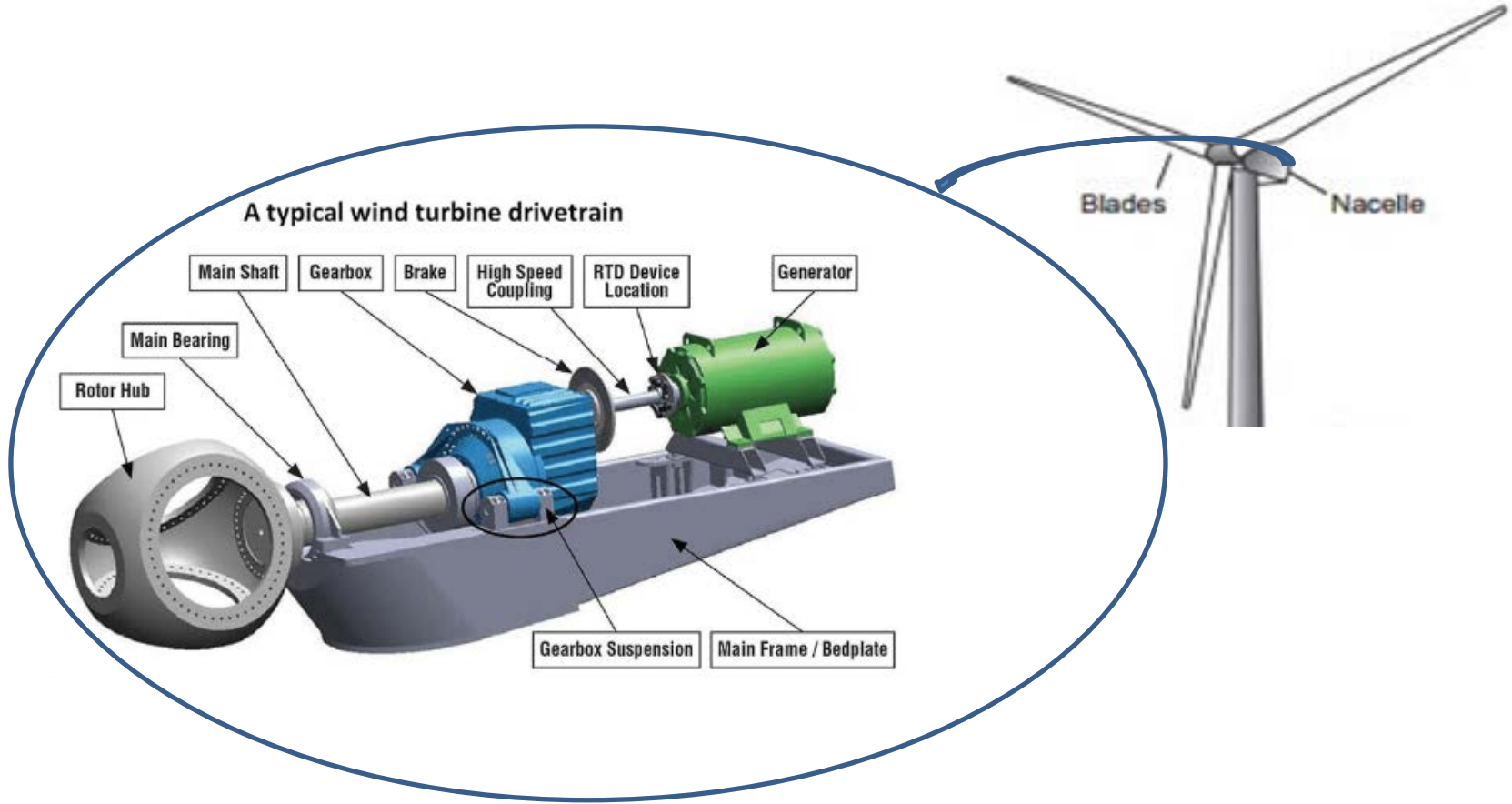

Gearbox	: 12,91 %
Generator	: 3,44 %
Hub-Rotor Blades	: 23,57 %
Main Shaft –Bearing	: 3,13 %
Transformer	: 3,59

EOW inceleme kapsamı

- Türbin bileşenlerinde görsel inceleme.
- Dişlikutusu endoscopy incelemesi
- Tahrik sistemi (Dişlikutusu-Rotor rulmanları-Jeneratör) vibrasyon analizi
- Kanat inceleme işlemleri
- Dişli ve gres yağı analizleri
- Elektriksel bağlantıların termal kamera ile incelenmesi
- Jeneratör-Dişlikutusu hizalama işlemleri
- Jeneratör testleri
- Trafo izolasyon direnç testi
- Temellerin görsel muayenesi ve bulgulara istinaden teknik inceleme yapılması

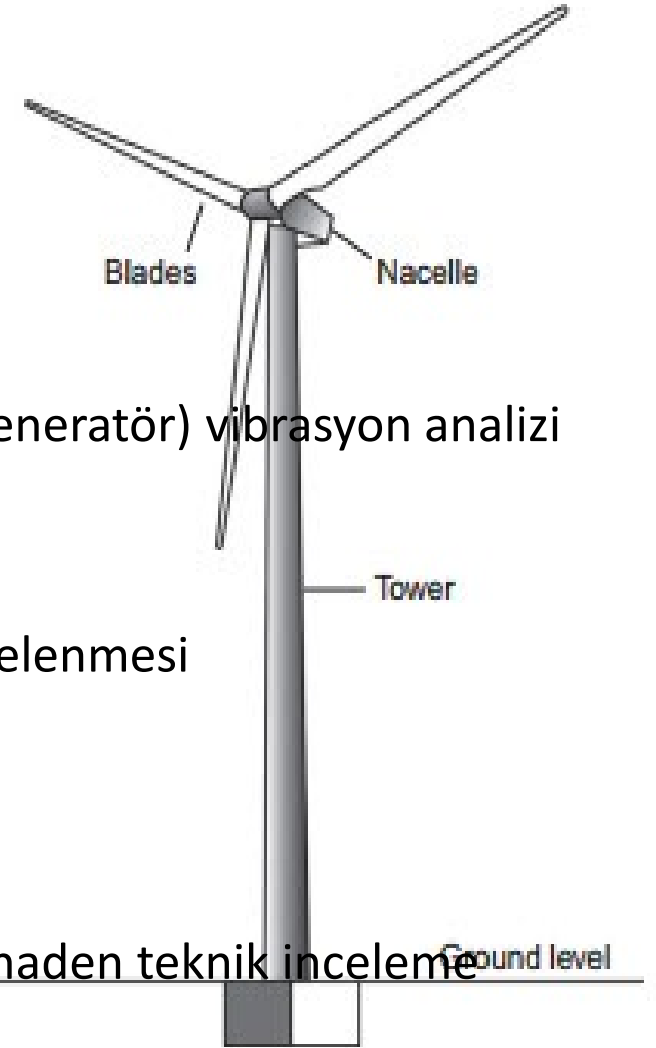

EOW inpection methods

- Borescope analizleri(Dişlikutusu ve Ana rulman)
- Titreşim analizi (Ana Rulman-Dişlikutusu- Generator)
- Yağ analizi (Dişlikutusu)
- Dişlikutusu- Jeneratör hizalama yöntemleri
- Termal kamera inceleme yöntemi



Dişlikutusu Endoscopy incelemeleri

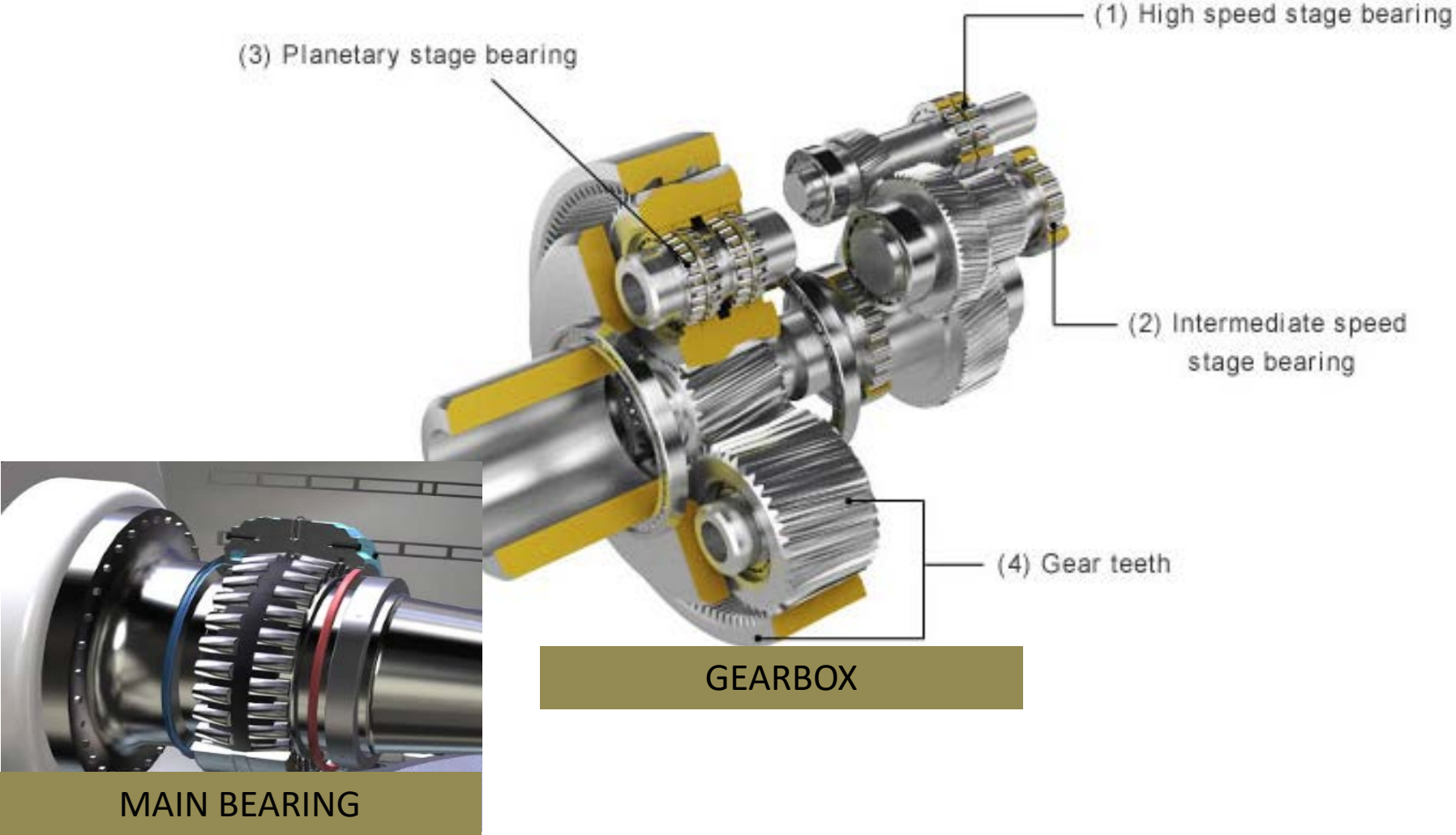

Dişlikutusu Borescope İncelemeleri



- ✓ Dişlikutusu incelemeleri
- ✓ Ana rulman incelemeleri
- ✓ Direct drive türbinlerinde jeneratör sargı incelemeleri



VİBRASYON ANALİZLERİ

- ✓ Ana yatak jeneratör rulmanları ve dişlikutusundaki anormalliklerin tespiti
- ✓ Çok kanallı ve aynı anda titreşim değerlerinin alınması

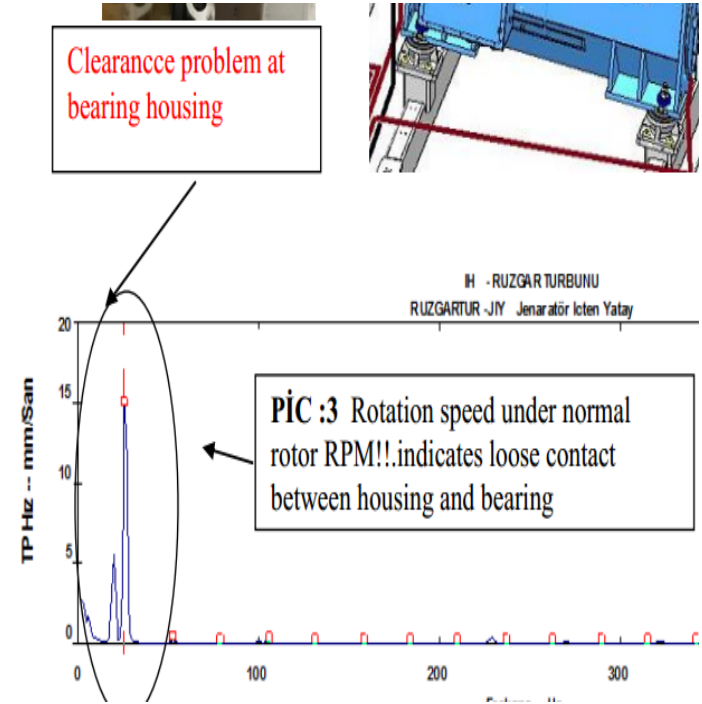

Yağ Analizi

Make:		Sample No:	1234567
Model:		Location:	UNITED KINGDOM
Serial No:	ABC123	Client:	HYDRAQUIP
System:	HYDRAULIC	Form No:	HQ123
Brand:		Job No.:	
Grade:		Sampled:	01/07/2014
Unique No.:	987654	Received:	02/07/2014
Diagnosis		Diagnosisian:	Riy: Normal Caution Serious
Copper exceed. Viscosity not consistent with stated grade. Visible debris present. Advice: Resample at the next service intervention.			
Results		Current Sample	Historical Samples
Sample No:		1234567	
Status:			
Sampled:		01/07/2014	
Fuel Age:		18.34	
Oil Age:			
Fluid Condition			
Viscosity @ 40 °C	mm ² /s		40.1
Appearance			Debris Present
PC Elements			
B (Boron)	mg/kg		41
Ba (Barium)	mg/kg		0.1
Ca (Calcium)	mg/kg		1334
Mg (Magnesium)	mg/kg		8.8
P (Phosphorus)	mg/kg		375
S (Sulphur)	mg/kg		5740
Zn (Zinc)	mg/kg		473
Contamination			
Particles >4µm	particles/ml		9620
Particles >6µm	particles/ml		840
Particles >14µm	particles/ml		35
Water	%		<0.1
ISO Code			2017/12
Na (Sodium)	mg/kg		3.3
K (Potassium)	mg/kg		0.9
Si (Silicon)	mg/kg		3.3
Li (Lithium)	mg/kg		0.3
Wear Metals			
Al (Aluminum)	mg/kg		0.8
Sn (Tin)	mg/kg		0.9
Pb (Lead)	mg/kg		1.6
Cu (Copper)	mg/kg		1.9
Fe (Iron)	mg/kg		5.0
Cr (Chromium)	mg/kg		0.3
Mo (Molybdenum)	mg/kg		2.9
Ag (Silver)	mg/kg		1.6
Ni (Nickel)	mg/kg		0.2
Mn (Manganese)	mg/kg		0.7
Ti (Titanium)	mg/kg		0.0
V (Vanadium)	mg/kg		0.0
Cd (Cadmium)	mg/kg		0.0



Kanat incelemeleri



Overview Picture



Detailed Picture (size must be visible)



- İple Erişim
- Yüksek çözünürlüklü kamera
- Kanat içi robot ile kanat içerisinin incelenmesi
- UT test ile kule kaynak bağlantılarının incelenmesi
- Drone ile kanat incelemeleri



Kule ve Kule Bağlantı elemanlarının incelenmesi

- Bağlantı elemanlarının kontrolü ve bulgulara göre teknik incelenmesi
- Kule kaynak birleşimlerinin kontrolü ve bulgulara göre teknik incelemesi
- Kule içerisi topraklama bağlantılarının kontrolü

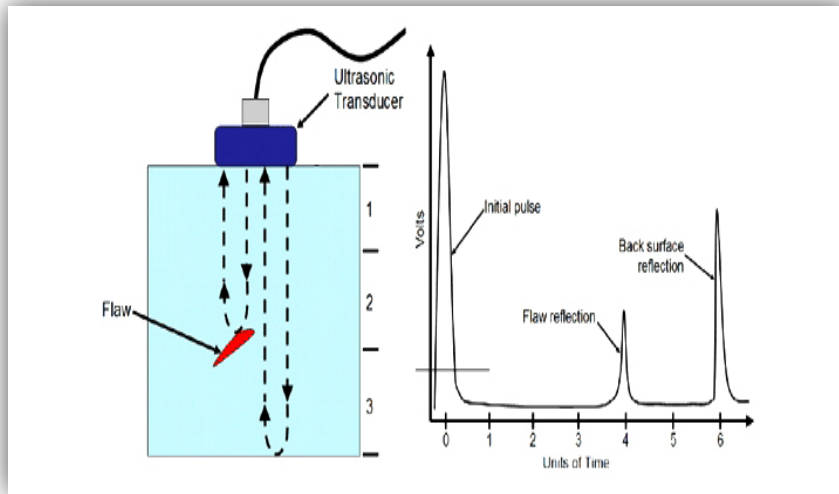

TERMAL KAMERA İNCELEME İŞLEMLERİ

- ✓ Kablo bağlantıları
- ✓ Kesici ve trafo bağlantıları
- ✓ Jeneratör elektrik bağlantıları
- ✓ Pano içi elektrik bağlantıları



Trafo izolasyon direnç testleri

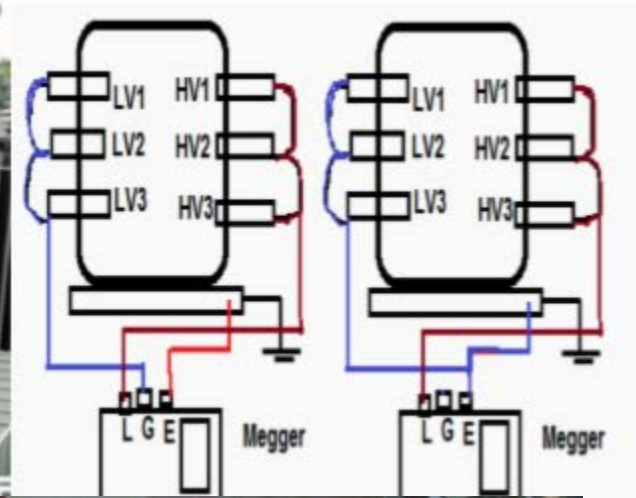

Hizalama teknikleri

Jeneratör-Diřlikutusu aksenal
kontrolleri
Kaplin ayarlarının yapılması



TEMEL KORUMA SİSTEMLERİ VE ANALİZLERİ

- Souplethane kaplama
- Çatlakların oluşumunun önlenmesi
- Dış ortamdan izole edilmesi
- Temel numunelerinin teknik analizleri
- Temel ve Kule bağlantı civatalarının tork kontrolleri



G R O U P
GENBA
all renewable
WIND SERVICES

Thank You

•**ROMANYA / ROMANIA**

Galati, Str. Portulul, Nr.43
bl. Catusa ap. 50 Romania
T: +40 743 829 288
E-mail: gts-eu@genba.com.tr

•**PAKİSTAN / PAKISTAN**

07, Chahudary St 3/1, Clifton
Colony, Lahore, Pakistan
T: +92 321 456 60 42
E-mail: gts-pakistan@genba.com.tr

•**FAS / MOROCCO**

Hay Al Qods Lotissement Issam
Sofia Rue Ouad Assbat Nr.02
Laayoune, Morocco
T: +212 662-421699
E-mail: gts-morocco@genba.com.tr

•**TÜRKİYE / TURKEY**

Gaziosmanpaşa OSB Mah.
Haddeciler OSB 2 Sk. No:13/2
Altıeylül / BALIKESİR
T: +90 266 221 48 85
Gsm: +90 545 349 82 13
E-mail: info@genba.com.tr

info@genba.com.tr • www.genba.com.tr

190 0001
BÜYÜK YERİTİM
Certification



190 1001
BÜYÜK YERİTİM
Certification



40000 10001
BÜYÜK YERİTİM
Certification

